



## Global® BS 470 Series – Button sewing machines

### TECHNICAL SPECIFICATIONS

Machine speed\*

1500 spm

Stitch type

103

Number of needles

1

Stitches per cycle

8 - 16 - 32

Needle type

1985

Buttons size

9 mm ø - 25 mm ø

Optional clamps available

snap fasteners B372-580

shank buttons B373-588

wrap around B373-651

stay buttons B372-663

**BS 472** - Single thread chainstitch button sewing machine, for sewing on flat 2 and 4 button holes.

Optional clamps for shank-stay-wrapped buttons and snap fasteners available.

**BS 473** - Single thread chainstitch button sewing machine, for sewing on flat 2 and 4 button holes.

Optional clamps for shank-stay-wrapped buttons and snap fasteners available.

Equipped with automatic underbed threadtrimmer.

### MAQUINAS BOTONERAS

**BS 472** - Máquina de puntada de cadeneta de un hilo para coser botones planos con 2 y 4 agujeros.

Opcional: Pinza para coser botones de anilla y corchetes.

**BS 473** - Máquina de puntada de cadeneta de un hilo para coser todo tipo de botones planos con

2 y 4 agujeros. Opcional: Pinza para coser botones de anilla y corchetes. Equipada con cortahilos automático.

### KNOPFANNÄHAUTOMAT

**BS 472** - Einfaden - Kettenstich Knopfannähautomat für 2-Loch und 4-Loch Knöpfen. Zusätzlich lieferbar:

- Stil ümwickelverrichtung

- Ösenknopfklammer.

**BS 473** - Einfaden - Kettenstich Knopfannähautomat für 2-Loch und 4-Loch Knöpfen. Ausgestattet mit

autom. Fadenabschneider. Zusätzlich lieferbar:

- Stil ümwickelverrichtung

- Ösenknopfklammer.

### MACHINES POUR POSER LES BOUTONS

**BS 472** - Machine pose boutons point de chainette à un fil, pour coudre les boutons plats à 2 ou 4 trous.

Disponibles en option pinces pour boutons à queue et agrafes rapides.

**BS 473** - Machine pose boutons point de chainette à un fil, pour coudre les boutons plats à 2 ou 4 trous.

Disponibles en option pinces pour boutons à queue et agrafes rapides. Equipée avec coupe-fils automatique.

## Global® BS 470 Series

High speed single thread chainstitch button sewing machines for general materials.  
For sewing 2 and 4 hole buttons.

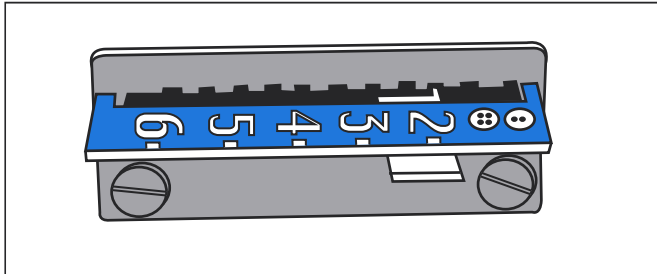

Lengthwise adjusting scale 2/4 hole

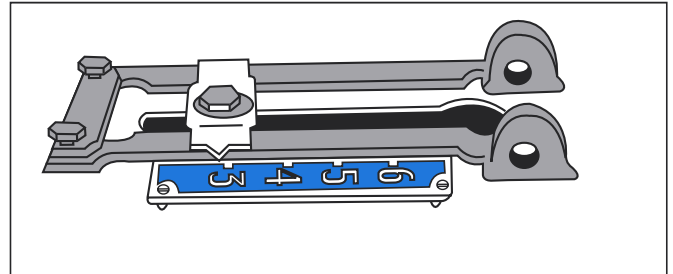

Crosswise adjusting scale

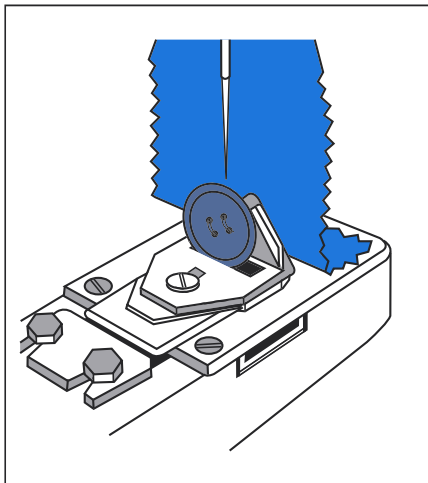

Attachment for wrapped-around buttons

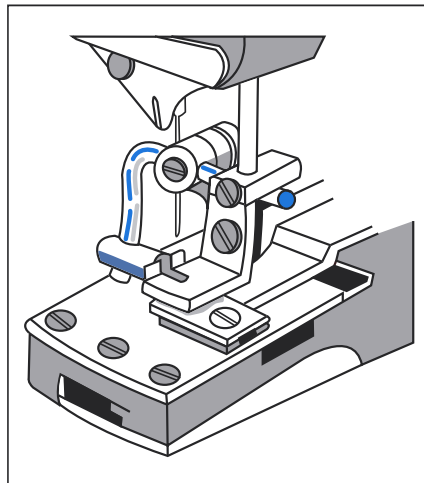

Attachment for shank buttons

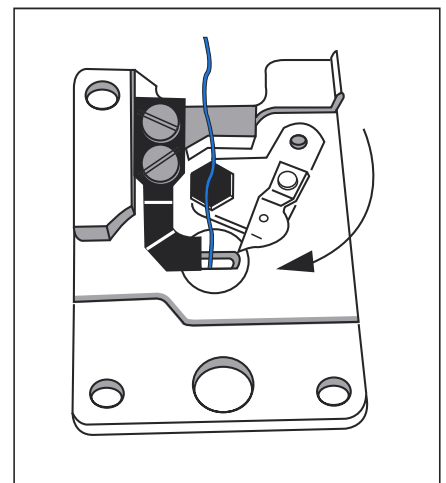

Thread cutter with a movable knife (BS 473)

### Specifications

model	needle bar stroke mm	number of stitches	max. sewing speed* spm	needle system	button size Ø	height of button clamp mm	sewing dimensions mm	thread cutter
BS 472	48.1	8 - 16 - 32	1500	1985	9 - 27	14	2.5 / 6.5	—
BS 473	48.1	8 - 16 - 32	1500	1985	9 - 27	14	2.5 / 6.5	•

★ Max. sewing speed (in spm.) depends on type of operation and/or materials to be sewn.

The GLOBAL® Selection is brought to you by:

GLOBAL® is a trademark of the Global International Corporation, the people that carefully organize the supply of spareparts before they launch each product.

When ordering parts please specify:

- ① machine model
- ② part numbers